Patch Panel, Modular Jack To 110Connect Block

1. SCOPE

1.1. Content

This specification covers performance, tests and quality requirements for NETCONNECT* Category 3 and Category 5 modular jacks to 110Connect patch panels used to connect building wiring for data and voice networking systems.

1.2. Qualification

When tests are performed on subject product line, procedures specified in Figure 1 shall be used. All inspections shall be performed using applicable inspection plan and product drawing.

1.3. Qualification Test Results

Successful qualification testing on the NETCONNECT* Category 3 and Category 5 modular jacks to 110Connect patch panels was completed on 15Nov96. The test file number for this testing is ACL 1962-006. This documentation is on file at and available from Americas Regional Laboratory.

2. APPLICABLE DOCUMENTS

The following documents form a part of this specification to the extent specified herein. Unless otherwise specified, the latest edition of the document applies. In the event of conflict between the requirements of this specification and the product drawing, the product drawing shall take precedence. In the event of conflict between the requirements of this specification and the referenced documents, this specification shall take precedence.

2.1. TE Connectivity (TE) Documents

- 109-1: General Requirements for Test Specifications
- 109 Series: Test Specifications as indicated in Figure 1
- 108-1163: Product Specification
- 108-1588: Product Specification
- 408-3269: Instruction Sheet
- 408-3343: Instruction Sheet
- 408-3359: Instruction Sheet
- 408-3388: Instruction Sheet
- 408-3391: Instruction Sheet
- 501-379: Qualification Test Report

2.2. Commercial Specification

- EIA/TIA-568-A, Annex A and B: Reliability of Connecting Hardware Used For 100 Ohm UTP Cabling
- EIA/TIA-TSB40-A: Transmission Testing Of Conducting Hardware For 100 Ohm UTP Cabling

3. REQUIREMENTS

3.1. Design and Construction

Product shall be of design, construction and physical dimensions specified on applicable product drawing.

3.2. Materials

Materials shall be as specified on applicable product drawing.

3.3. Ratings

- Voltage: 150 volts AC
- Current: Signal application only
- Temperature: -40 to 70°C

3.4. Performance and Test Description

Product is designed to meet electrical, mechanical and environmental performance requirements specified in Figure 1. Unless otherwise specified, all tests shall be performed at ambient environmental conditions per Test Specification 109-1.

3.5. Test Requirements and Procedures Summary

Test Description	Requirement	Procedure
Examination of product.	Meets requirements of product drawing.	Visual, dimensional and functional per applicable quality inspection plan.
ELECTRICAL		
Termination resistance.	20 milliohms maximum increase.	TE Spec 109-6-6. Subject mated contacts assembled in housing to 20 mv maximum open circuit at 100 ma maximum. See Figure 3.
Insulation resistance.	100 megohms minimum.	TE Spec 109-28-4. Test between adjacent contacts of mated samples.
NEXT loss (crosstalk).	See Figure 4.	EIA/TIA-TSB40-A EIA/TIA-568-A
Attenuation.	See Figure 4.	EIA/TIA-TSB40-A EIA/TIA-568-A
Return loss.	See Figure 4.	EIA/TIA-TSB40-A EIA/TIA-568-A
MECHANICAL		
Vibration, sinusoidal.	No discontinuities of 1 microsecond or longer duration. See Note.	TE Spec 109-21-1. Subject mated samples to 10-55-10 Hz traversed in 5 minutes. 1 hour and 45 minutes in each of 3 mutually perpendicular planes. See Figure 5.

Figure 1(continued)

Test Description	Requirement	Procedure
Physical shock.	No discontinuities of 1 microsecond or longer duration. See Note.	TE Spec 109-26-1. Subject mated samples to 30 G's half-sine shock pulses of 11 milliseconds duration. 3 shocks in each direction applied along 3 mutually perpendicular planes, 18 total shocks. See Figure 5.
Durability.	See Note.	TE Spec 109-27. Mate and unmate samples for 200 cycles at maximum rate of 600 cycles per hour. Modular jack/plug meet 750 mating and unmating cycles per AMP Specification 108-1163. 110Connect block meet 200 terminate and unterminate cycles per AMP Specification 108-1588.

ENVIRONMENTAL

Thermal shock.	See Note.	TE Spec 109-22. Subject mated samples to 100 cycles between -40 and 70°C with 30 minutes at each temperature extreme.
Humidity-temperature cycling.	See Note.	TE Spec 109-23-4, Condition B. Subject mated samples to 21 cycles between 25 and 65°C at 95% RH.
Temperature life.	See Note.	TE Spec 109-43. Subject mated samples to temperature life at 70°C for 500 hours.

NOTE

Shall meet visual requirements, show no physical damage and shall meet requirements of additional tests as specified in Test Sequence in Figure 2.

Figure 1 (end)

3.6. Product Qualification and Requalification Test Sequence

Test or Examination	Test Group (a)				
	1	2	3	4	5
	Test Sequence (b)				
Examination of product	1,6	1,5	1,8	1,6	1,5
Termination resistance	2,5	2,4	2,7		
Insulation resistance				2,5	
NEXT loss (crosstalk)					2
Attenuation					3
Return loss					4
Vibration	3				
Physical shock	4				
Durability			3,6(c)		
Thermal shock			4	3	
Humidity-temperature cycling			5	4	
Temperature life		3			

- NOTE**
- (a) See paragraph 4.1.A.
 - (b) Numbers indicate sequence in which tests are performed.
 - (c) Perform 100 cycles before thermal shock, 33 cycles after 50 cycles of thermal shock, 33 cycles after 7 days of humidity-temperature cycling, and 34 cycles after 21 days.

Figure 2

4. QUALITY ASSURANCE PROVISIONS

4.1. Qualification Testing

A. Sample Selection

Samples shall be prepared in accordance with applicable Instruction Sheets and shall be selected at random from current production. All test groups shall each consist of a minimum of 5 samples.

B. Test Sequence

Qualification inspection shall be verified by testing samples as specified in Figure 2.

4.2. Requalification Testing

If changes significantly affecting form, fit or function are made to the product or manufacturing process, product assurance shall coordinate requalification testing, consisting of all or part of the original testing sequence as determined by development/product, quality and reliability engineering.

4.3. Acceptance

Acceptance is based on verification that the product meets the requirements of Figure 1. Failures attributed to equipment, test setup or operator deficiencies shall not disqualify the product. When product failure occurs, corrective action shall be taken and samples resubmitted for qualification. Testing to confirm corrective action is required before resubmittal.

4.4. Quality Conformance Inspection

The applicable quality inspection plan will specify the sampling acceptable quality level to be used. Dimensional and functional requirements shall be in accordance with applicable product drawing and this specification.

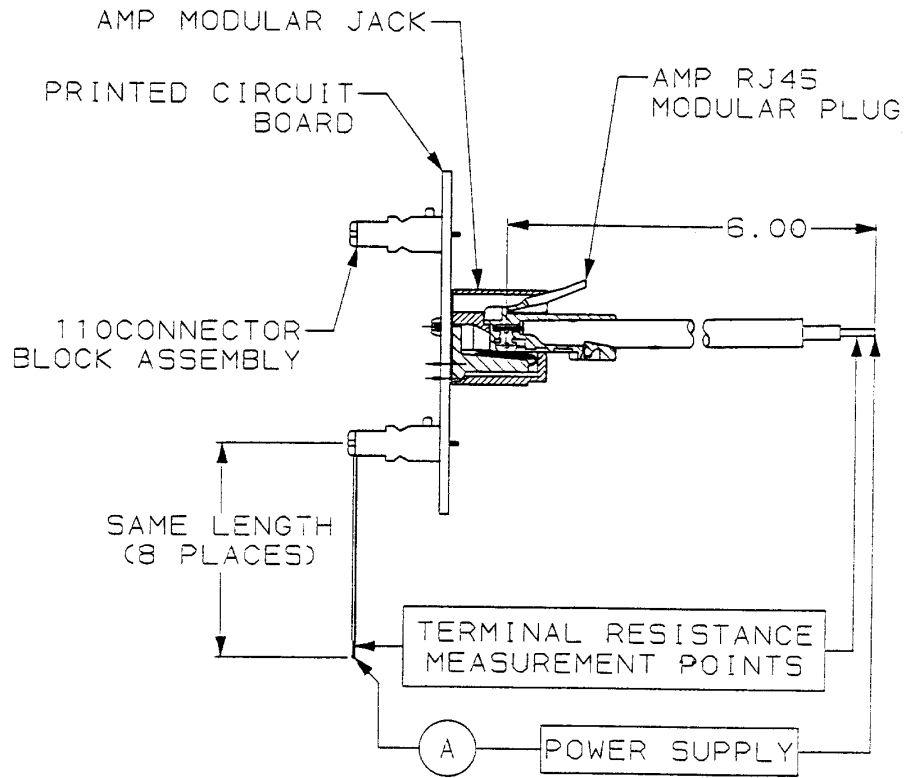

Figure 3
Termination Resistance Measurement Points

Category 5, 100 Ohm Twisted Pair (See Note)			
Frequency (MHZ)	NEXT Loss (crosstalk) (dB)	Attenuation (dB)	Return Loss (dB)
1.0	65	0.1	≥23
4.0	65	0.1	≥23
8.0	62	0.1	≥23
10.0	60	0.1	≥23
16.0	56	0.2	≥23
20.0	54	0.2	≥23
25.0	52	0.2	≥14
31.25	50	0.2	≥14
62.5	44	0.3	≥14
100.0	40	0.4	≥14

NOTE See EIA/TIA-TSB40-A and EIA/TIA-568-A.

Figure 4

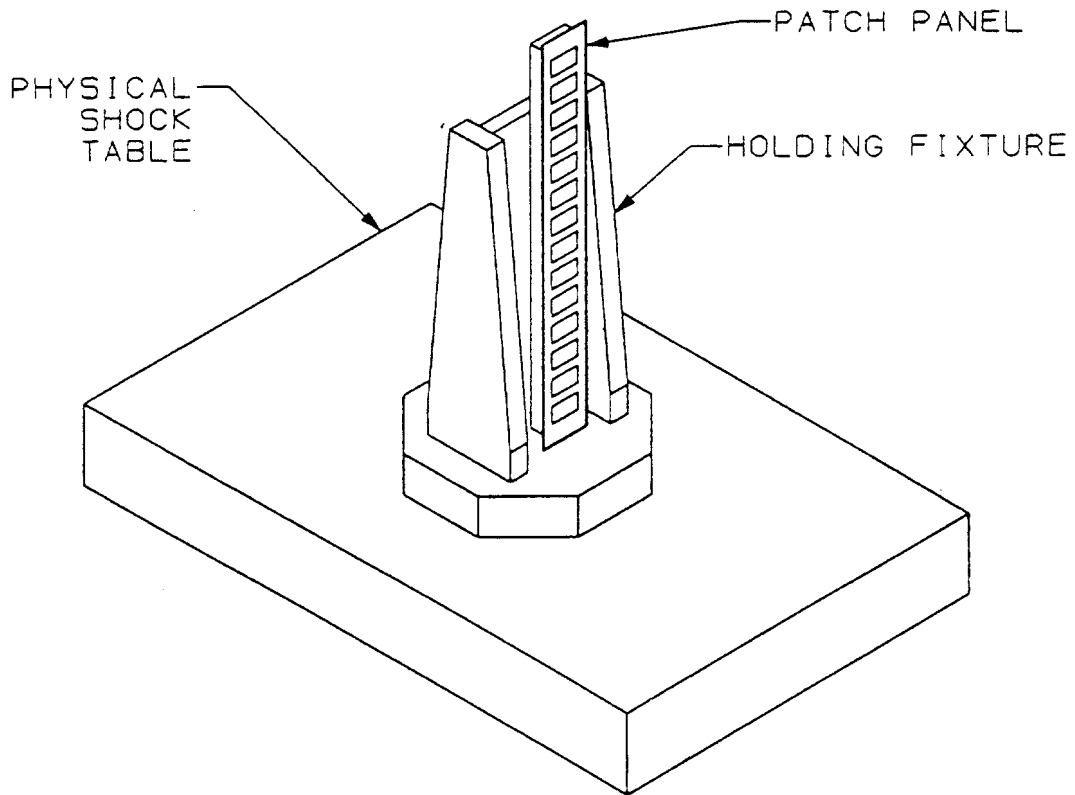
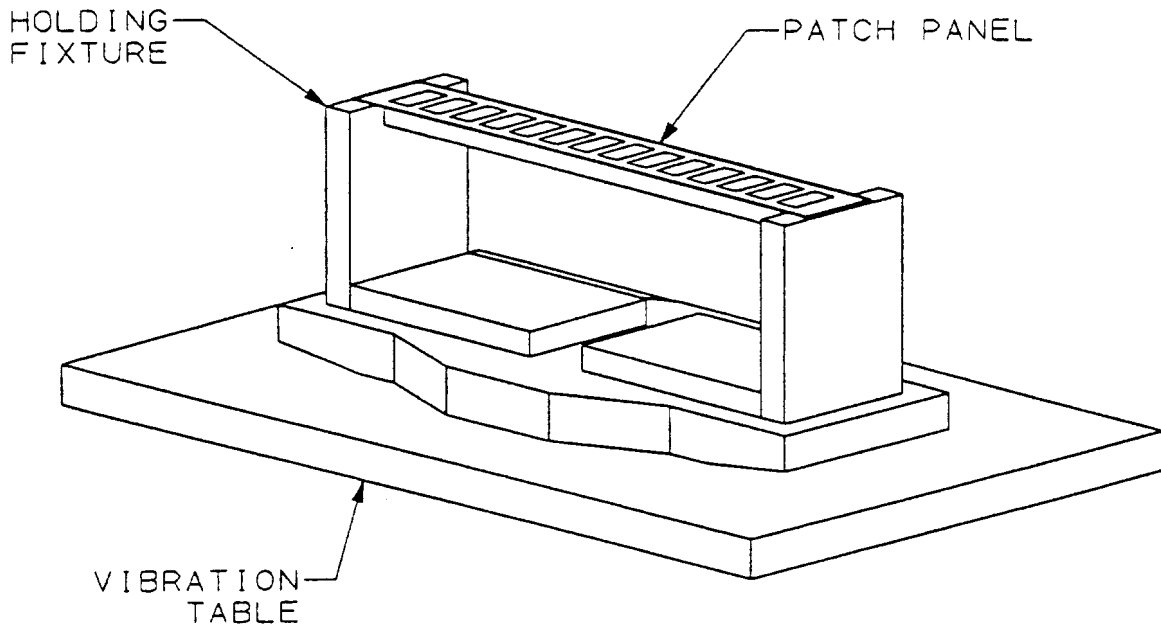

Figure 5
Vibration & Physical Shock Mounting Fixtures